

ABCEG



# Diesel Engine Driven Self Priming Centrifugal Pump

## Model 82E1-L100EE-X

### Size 2" x 2"



Total Head		Capacity Of Pump in U.S. Gallons Per Minute (GPM) at Continuous Performance				
P.S.I.	Feet					
61.6	142	44	44	44	44	44
60.7	140	52	52	52	52	52
52.0	120	80	115	139	140	140
43.4	100	80	118	145	174	184
34.7	80	81	120	147	178	200
26.0	60	82	120	147	178	210
17.3	40	82	121	148	178	214
<b>Suction Lift</b>		<b>25'</b>	<b>20'</b>	<b>15'</b>	<b>10'</b>	<b>5'</b>



#### PUMP SPECIFICATIONS

**Size:** 2" x 2" NPT (51 mm x 51 mm) - Female.  
**Casing:** Aluminum No. 356-T6 with Gray Iron No. 30 Cutwater Insert. Maximum Operating Pressure 98 psi (676 kPa). \*  
**Open Type, Four Vane Impeller:** Aluminum No. 356-T6 Handles 3/4" (19 mm) Diameter Spherical Solids.  
**Replaceable Wear Plate:** Carbon Steel No. M1026.  
**Intermediate Bracket:** Gray Iron No. 30.  
**Seal:** Type 1, Mechanical, Self-lubricated. Carbon Rotating Face. Ni-Resist Stationary Face. Fluorocarbon Elastomers (DuPont Viton® or Equivalent). Stainless Steel No. 18-8 Cage and Spring. Maximum Temperature of Liquid Pumped, 160°F (71°C). \*  
**Shaft Sleeve:** Alloy Steel No. 4130.  
**Flap Valve:** Gray Iron No. 30, Steel and Nitrile/Nylon Reinforcement.  
**Flange:** Aluminum No. 356-T6.  
**Gaskets:** Cork.  
**Hardware:** Standard Plated Steel.

**Standard Equipment:** 90° Ductile Iron Discharge Elbow. Rollover Base with Rubber Feet.

**Optional Equipment:** Two Wheel Truck Assembly with 10.00" x 2.75" (254 mm x 70 mm) Semi-Pneumatic Tires.

*\*Consult Factory for Applications Exceeding Maximum Pressure and/or Temperature Indicated.*

WARNING!

This unit is designed to handle volatile, flammable liquids. To reduce the risk of fire or explosion, do not operate near open flames, sparks, cigarettes or any other ignition source. Do not operate the unit in an explosive atmosphere or unventilated area. Connect the attached ground cable to the nearest grounding point on the tank being filled. Shut off the engine and allow it to completely cool before refueling.

#### ENGINE SPECIFICATIONS

**Model:** Yanmar L100EE.  
**Type:** Single Cylinder, Four Cycle, Air Cooled, Diesel Engine.  
**Displacement:** 25.5 Cu. In. (418 cc).  
**Governor:** Variable Speed, Engine Mounted.  
**Lubrication:** Forced Circulation.  
**Air Cleaner:** Dry Type.  
**Oil Reservoir:** 1.74 U.S. Qts. (1,65 liter).  
**Fuel Tank:** 1.45 U.S. Gals. (5,5 liter).  
**Full Load Operating Time:** 2.1 Hrs.  
**Starter:** Rope Rewind.

**Standard Features:** Muffler Heat Shield and Fuel Splash Guard. 90° Exhaust Deflector. Exhaust Silencer Muffler w/Guard. Tool Kit. Grounding Wire.

#### YANMAR PUBLISHED PERFORMANCE:

Maximum Continuous BHP 9 (6,6 kW) @ 3600 RPM  
 Maximum Dynamic BHP 10 (7,4 kW) @ 3600 RPM



COURTESY OF  
**MASCOTT EQUIPMENT COMPANY**  
 Portland Seattle Tri-Cities  
[www.mascottec.com](http://www.mascottec.com)

**Specification Data**

**SECTION 20, PAGE 278**

APPROXIMATE  
DIMENSIONS and WEIGHTS

**NET WEIGHT:** 192 LBS. (87 KG.)  
**SHIPPING WEIGHT:** 248 LBS. (112 KG.)  
**EXPORT CRATE SIZE:** 22.7 CU. FT. (0,6 CU. M.)  
 WHEEL KIT ADD 22 LBS. (10 KG.); SHIPPING CRATE (SEPARATE) 3 CU. FT. (0,1 CU. M.).

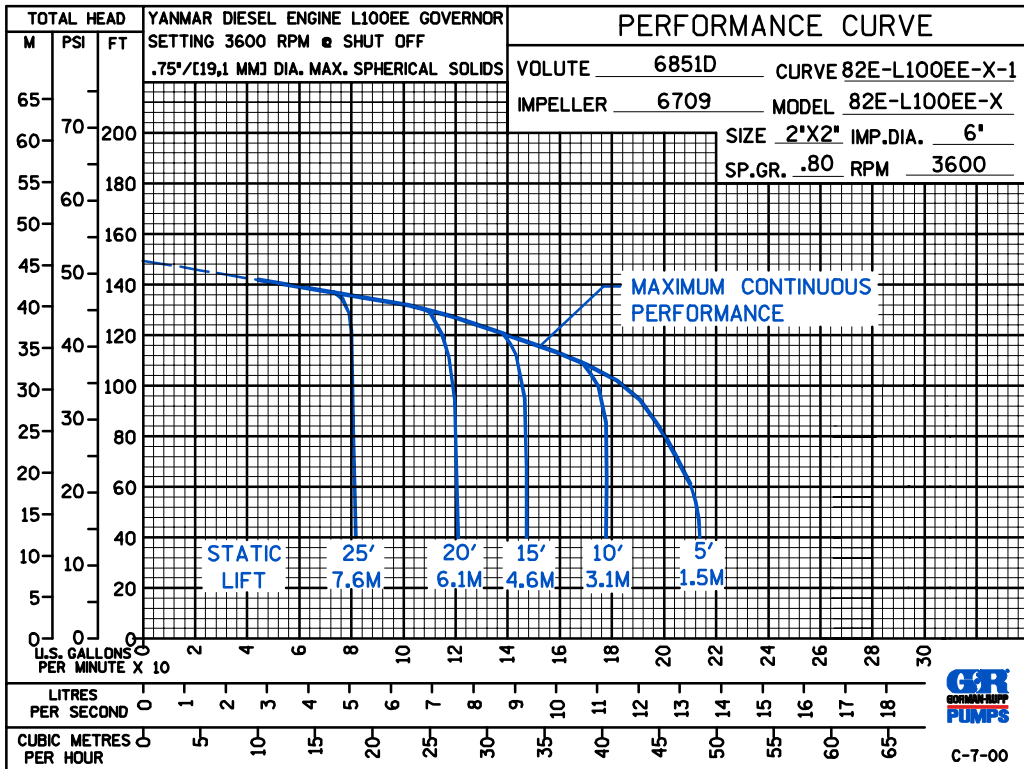
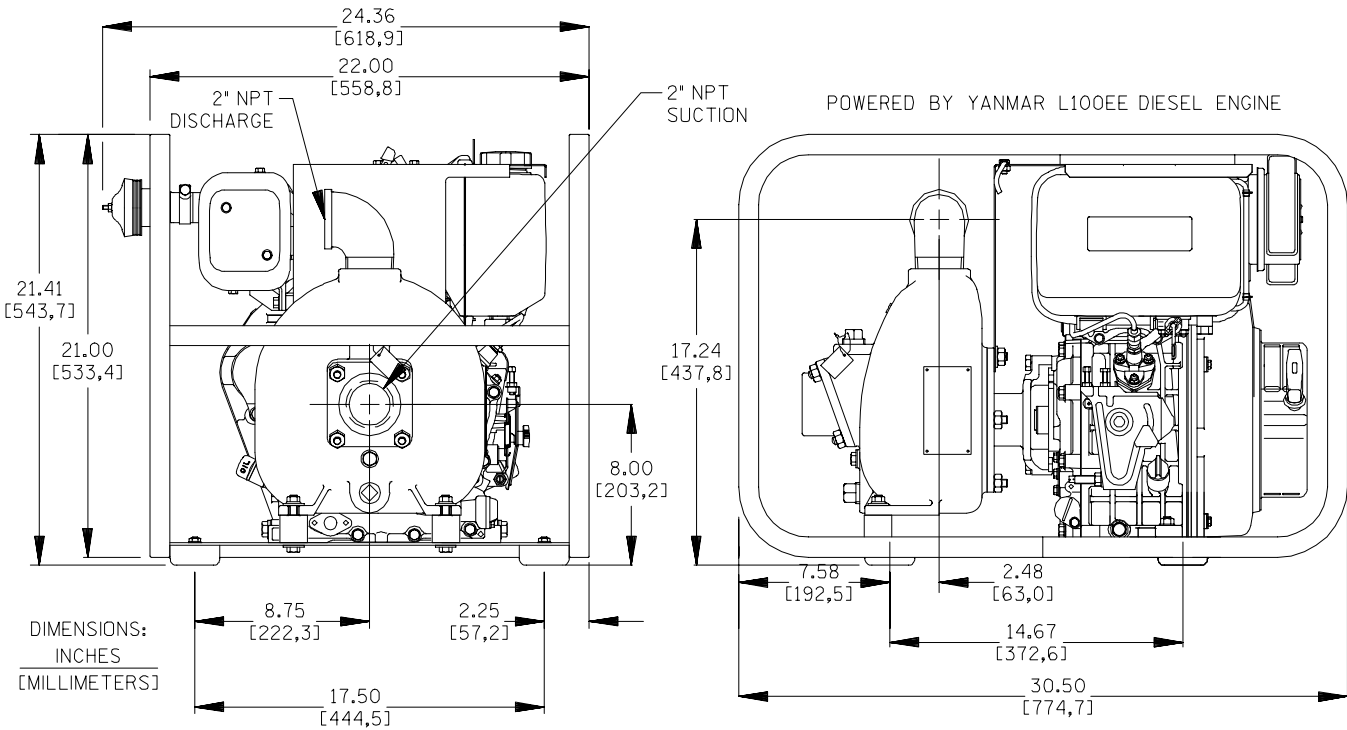

Printed in U.S.A.